

Manufactured in the UK, to meet the demands of commercial kitchens around the world.

Precision's high performance, easy to use and energy efficient Blast Chiller / Freezers have been designed to provide cost effective and reliable Chilling and Freezing solutions.

Available in under counter, counter and reach-in models with chilling capacities ranging from 10 to 35 KG per 90 minute chilling or 240 minute freezing cycle. All models accommodate 1/1 gastronorm pans.

The intuitive microprocessor controlled digital control panel requires little or no staff training and offers the choice of Soft Chill, Hard Chill and Blast Freeze modes, along with HACCP capability. Blast cycles can be controlled by time or food temperature - via the internal food probe - and Chill or Freeze storage functions can be chosen when unit is not Blast chilling / freezing. The appropriate storage mode starts automatically at the end of each Blast cycle.

The self contained bottom mounted 43°C ambient refrigeration system can be easily accessed for servicing whilst the internal evaporator fans ensure even chilling / freezing throughout the cabinet. Defrost is automatic and our vaporiser system eliminates the need for a drain.



Thoughtful Design Features

These include: Energy efficient 35KG capacity machine can be plugged into a standard 13amp socket without the need for an expensive dedicated electrical supply. A standard 90 minute Blast Chill cycle is launched by simply pressing two buttons.



Gastronorm Shelving

A self-closing door, with removable magnetic balloon type gasket, provides access to a Gastronorm 1/1 shelving system. GN 1/1 pans are supported on removable anti-tilt stainless steel slides and ladder racking.

Under Counter or Counter Options

precision Blast Chillers are available in both under counter and counter versions. The counter model has a top mounted control panel located at the back of the work surface. All models are mounted on heavy duty, anti-slide brake and swivel castors, as standard.

General Specifications

High ambient (43°C) refrigeration system
 Easy to use digital control panel
 Time or food probe controlled cycle
 Chill or freeze storage mode
 Hot gas defrost
 Automatic vaporiser
 Stainless steel interior and exterior
 Zero ODP injected polyurethane insulation
 1/1 gastronorm shelving system (pans not supplied)
 Removable racking with anti-tilt slides
 Removable magnetic door gasket
 Heavy duty brake and swivel castors
 Energy efficient EC Technology

Options

GN 1/1 nylon coated shelves
 ST/ST back
 Helicoil cable
 L / R hinge
 Legs / castors

Temperatures

Blast Chill +90 / +3°C in 90 minutes
 Chill Store 0 / +3°C
 Blast Freeze +90 / -18°C in 240 minutes
 Freeze Store -18 / -20°C

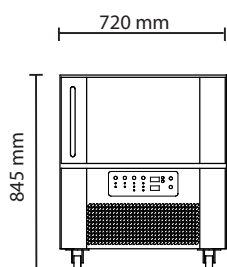

PCF 103

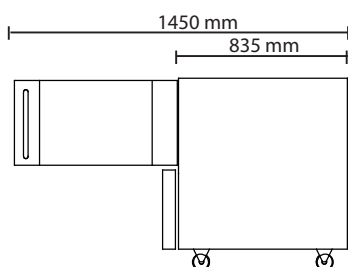

PCF 103

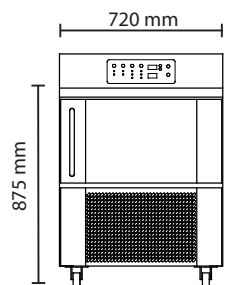

PCF 103 T

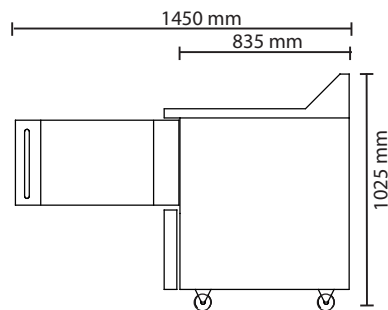

PCF 103 T

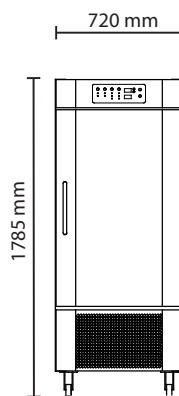

PCF 351

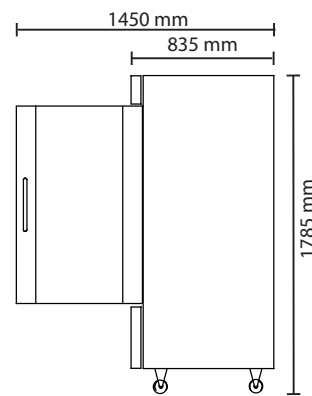

PCF 351

Technical Data

model	temp. °C	capacity kg	w mm	d mm	h mm	gas	slides pairs	ref. cap. watts	evap. @ °C	power	amps	wt. kg
Under Counter Blast Chiller / Freezer												
PCF 103 SS	+90 / +3°C	10	720	835	845	R404A	3	1679	-5°C	240 / 50 / 1	3.9	85
Counter Blast Chiller / Freezer												
PCF 103 T SS	+90 / +3°C	10	720	835	1025	R404A	3	1679	-5°C	240 / 50 / 1	3.9	85
Reach-in Blast Chiller / Freezer												
PCF 351 SS	+90 / +3°C	35	720	835	1785	R404A	10	2945	-5°C	240 / 50 / 1	6.0	180