

Manufactured in the UK, to meet the demands of commercial kitchens around the world.

Precision Under Broiler Counters are designed to provide refrigerated storage, in easy pull-out drawer formats, under the chargrill or griddle within the cooking line. This reduces non productive time and congestion within the kitchen giving staff refrigerated storage right where they need it within the cooking line.

These durable, all stainless steel Gastronorm counters provide commercial caterers with a choice of GN 1/1 or 2/1 drawers providing safe storage between 1 / 4°C.

A 43°C high ambient refrigeration system - managed by an electronic controller - provides accurate temperature control and peace of mind 24 hours a day. Audio visual temperature alarms come as standard, along with HACCP capability.

The self contained side-mounted refrigeration system draws from the front and vents at the rear. Defrost is automatic and our energy saving waste heat vaporiser system eliminates the need for a drain.



Thoughtful Design Features

Including evaporators which are located in the "dead" space behind the door mullion providing better use of space and superior cooling. This ensures a constant positive airflow that never has to blow across more than one section.

Cleaning

Easy cleaning has been made possible with removable stainless steel drawers and supports together with easy access to the refrigeration condenser for service and maintenance.

Worktop Options

precision counters are designed so they can be supplied with numerous worktop options; or even no worktop at all. Custom sized worktops can be ordered to accommodate specific site conditions or equipment layouts.

General Specifications

High ambient (43°C) refrigeration system
 Electronic controller with alarms
 Automatic off cycle defrost
 Stainless steel interior and exterior
 Zero ODP injected polyurethane insulation
 2/1 & 1/1 gastronorm drawer systems
 Coved interior and base
 Removable magnetic gaskets
 Right hand condensing unit
 Heavy duty brake and swivel castors

Options

Extended / Custom worktops
 Remote condensing unit - R
 ST/ST back
 Plinth mount options
 150 / 100 / 25mm Legs / Feet
 Helicoil cable

Temperatures

Refrigerators (H) 1 / 4 C

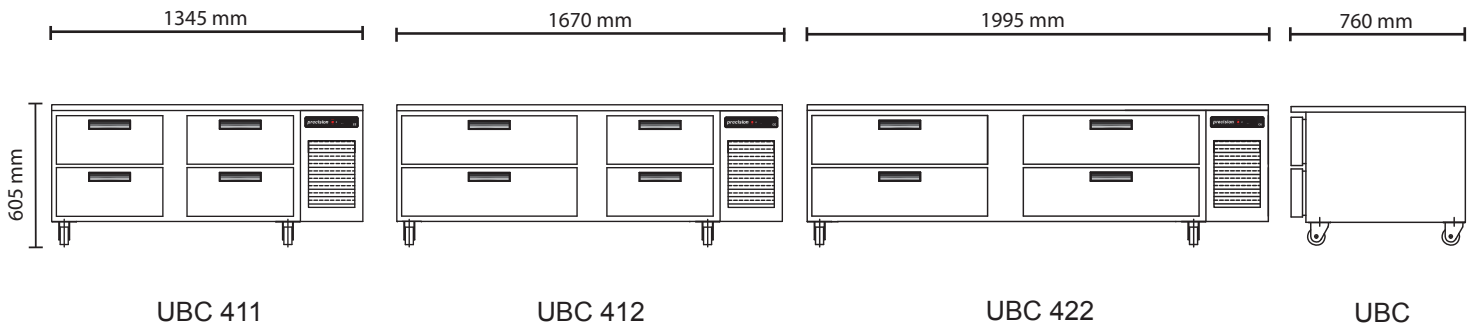

Technical Data

model	temp. °C	nom. cap. DRAWERS	l mm	d mm	h mm	gas	1/1 GN PANS	ref. cap. watts	evap. @ °C	power	amps	wt. kg
UNDER BROILER COUNTER												
UBC 411	1 / 4 C	4 x GN 1/1	1345	760	605	R134A	4	529	-5 C	240 / 50 / 1	3.0	110
UBC 412	1 / 4 C	2x1/1 & 2x2/1	1670	760	605	R134A	6	529	-5 C	240 / 50 / 1	3.0	140
UBC 422	1 / 4 C	4x GN 2/1	1995	760	605	R134A	8	529	-5 C	240 / 50 / 1	3.0	170

Note: remote models are shorter in length - CONTACT SALES TEAM