

Manufactured in the UK, to meet the demands of commercial kitchens around the world.

Precision Prep Counters provide the best in refrigerated preparation counters whether it be for salads, pizzas, sandwiches, tapas, desserts and much more.

These durable, all stainless steel Prep Counters incorporate a truly effective cold air distribution system ensuring a food storage temperature of 4°C in both pans and storage area to meet HACCP temperature requirements.

The PPC is available in 3 and 4 door models with your choice of Gastronorm 1/1 door or drawer configurations. All benefit from a retractable cover blind to reduce energy consumption and maintain safe food temperatures for longer periods.

The self contained rear-mounted refrigeration system is managed by Precision's iCool energy saving controller providing accurate temperature control, audio visual temperature alarms as well as HACCP capability.

Defrost is automatic and waste water is vaporised automatically.



Thoughtful Design Features

A concealed retractable pan cover has been incorporated, rather than a hinged or removable cover, allowing prep counters to be positioned under a "pass".

Door & Drawer Configurations

Self-closing doors can be replaced with banks of 2 or 3 Gastronorm 1/1 drawer sets. All counter doors can accept a drawer set offering superior utilisation of available storage space. Stainless steel drawers, shelf slides and ladder racking are easily removed for cleaning.

Mobility

Precision prep counters are mounted on heavy duty, anti-slide brake and swivel castors, as standard. This provides mobility for easy cleaning whilst the castor's locking function ensures stability once unit is set in place. Legs are available as a no cost option.

General Specifications

- High ambient (43°C) refrigeration system
- iCool Energy saving controller
- High/Low temperature alarms
- Automatic electric defrost
- Stainless steel interior and exterior
- Zero ODP injected polyurethane insulation
- Pan well to suit 1/3 GN pans
- Retractable night blind
- Removable magnetic gaskets
- Rear mounted condensing unit
- Heavy duty brake and swivel castors

Options

- Bank of 2 drawers (NON-LOCKING)
- Bank of 3 drawers (NON-LOCKING)
- 1/3 GN pan set
- ST/ST back
- Helicoil cable

Temperatures

Refrigerators (H) 1 / 4 C

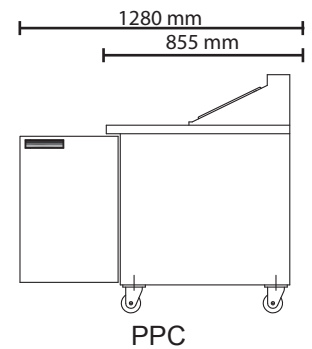
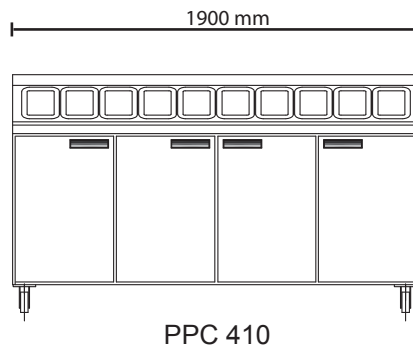
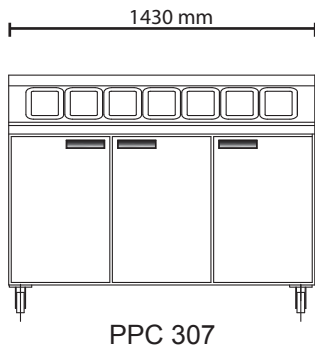

Technical Data

model	temp. °C	nom. cap. 1/3 PANS	l mm	d mm	h mm	gas	shelves	ref. cap. watts	evap. @ °C	power	amps	wt. kg
Prep Counter												
PPC 307	1 / 4 C	7	1430	905	1085	R134a	6	530	-10 C	240 / 50 / 1	3.3	140
PPC 410	1 / 4 C	10	1900	905	1085	R134a	8	700	-10 C	240 / 50 / 1	3.8	170

Note: unit requires rear / top ventilation